

DIN 985 similar to ISO 10511

Hexagon nuts

With clamping part | non-metallic insert | low form

Steel 08 | zinc-plated, thick-film passivated (VZD) | Cr(VI)-free | Metric thread

Further information: DIN standard has been withdrawn | changed nut height and wrench width

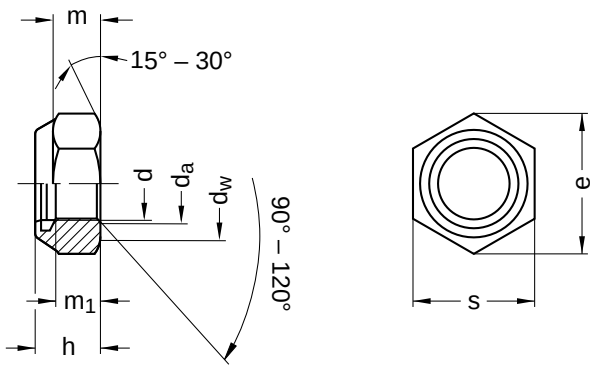

Diameter (d)	d _a		d _w min.	h		m ₁ min.	e min.	m min.	s		Pitch (P)	Tool size
	min.	max.		min.	max.				min.	max.		
M3	3	3.45	4.6	3.70	4	1.65	6.01	2.4	5.32	5.5	0.50	SW 5,5
M4	4	4.60	5.9	4.70	5	2.20	7.66	2.9	6.78	7.0	0.70	SW 7
M5	5	5.75	6.9	4.70	5	2.75	8.79	3.2	7.78	8.0	0.80	SW 8
M6	6	6.75	8.9	5.70	6	3.30	11.05	4.0	9.78	10.0	1.00	SW 10
M8	8	8.75	11.6	7.64	8	4.40	14.38	5.5	12.73	13.0	1.25	SW 13
M10	10	10.80	15.6	9.64	10	5.50	18.90	6.5	16.73	17.0	1.50	SW 17
M12	12	13.00	17.4	11.57	12	6.60	21.10	8.0	18.67	19.0	1.75	SW 19
M14	14	15.10	20.5	13.30	14	7.70	24.49	9.5	21.67	22.0	2.00	SW 22
M16	16	17.30	22.5	15.30	16	8.80	26.75	10.5	23.67	24.0	2.00	SW 24
M20	20	21.60	27.7	18.70	20	11.00	32.95	14.0	29.16	30.0	2.50	SW 30
M24	24	25.90	33.2	22.70	24	13.20	39.55	15.0	35.00	36.0	3.00	SW 36

All technical data refer to the measure mm

