

DIN 562

Vierkantmuttern

niedrige Form

Edelstahl A2 | Cr(VI) - frei | Metrisches Gewinde

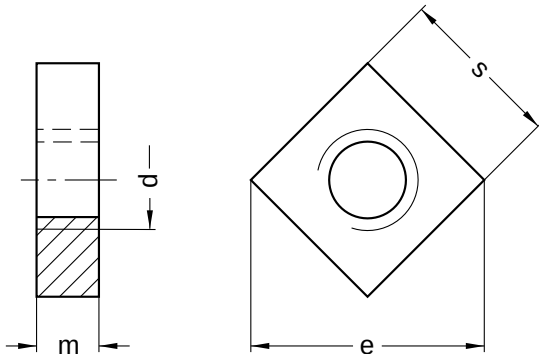

Durchmesser (d)	e		m		s		Steigung (P)
	min.	max.	min.	max.	min.	max.	
M2	5,0	0,80	1,2	3,70	4,0	0,40	
M2,5	6,3	1,20	1,6	4,70	5,0	0,45	
M3	7,0	1,40	1,8	5,20	5,5	0,50	
M4	8,9	1,80	2,2	6,64	7,0	0,70	
M5	10,2	2,30	2,7	7,64	8,0	0,80	
M6	12,7	2,72	3,2	9,64	10,0	1,00	
M8	16,5	3,52	4,0	12,57	13,0	1,25	
M10	20,2	4,52	5,0	15,57	16,0	1,50	

Alle technischen Daten beziehen sich auf das Maß mm

